

No. 662,412.

Patented Nov. 27, 1900.

E. GATES.
MAGNETIC SEPARATOR.

(Application filed Apr. 14, 1900.)

(No Model.)

Fig. 1.

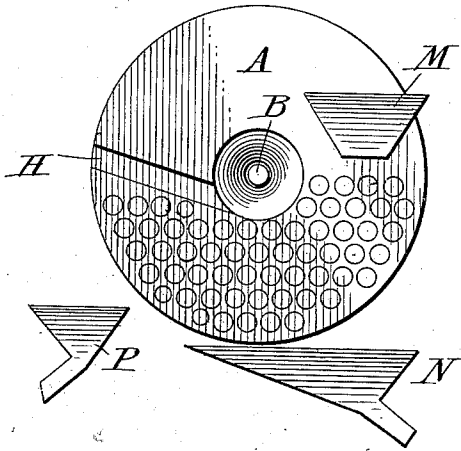

Fig. 2.

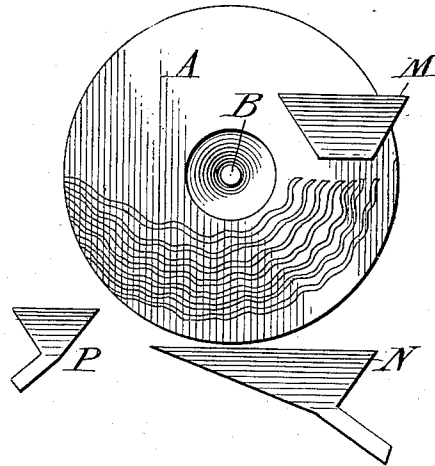
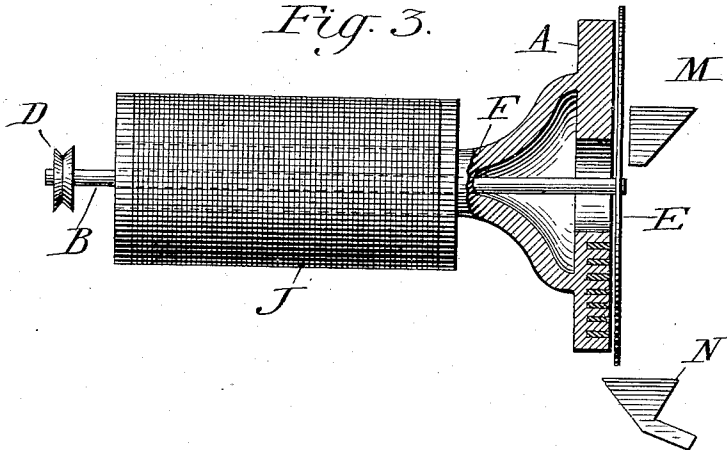

Fig. 3.



Witnesses:
D. W. Edlin,
J. C. Hutchinson, Jr.

Inventor:
Elihu Gates,
by Lemuel F. Goldsborough,
Attys.

UNITED STATES PATENT OFFICE.

ELMER GATES, OF CHEVY CHASE, MARYLAND, ASSIGNOR TO THEODORE J. MAYER, OF WASHINGTON, DISTRICT OF COLUMBIA.

MAGNETIC SEPARATOR.

SPECIFICATION forming part of Letters Patent No. 662,412, dated November 27, 1900.

Application filed April 14, 1900. Serial No. 12,905. (No model.)

To all whom it may concern:

Be it known that I, ELMER GATES, a citizen of the United States, residing at Chevy Chase, county of Montgomery, State of Maryland, have invented certain new and useful Improvements in Magnetic Separators; and I do hereby declare the following to be a full, clear, and exact description of the invention, such as will enable others skilled in the art to which it appertains to make and use the same.

In an application filed by me March 19, 1900, Serial No. 9,269, I have described and shown an apparatus for separating diamagnetic material from paramagnetic material— as, for instance, free particles of gold or copper from magnetic iron ore or sand from magnetic iron ore—by feeding the material to be separated over the face of an electromagnet energized to a degree just sufficient to cause the magnetic particles to assume a moss-like or frond-like structure, thereby disentangling the diamagnetic particles. The moss-like or frond-like structures are then caused to continuously rearrange themselves upon their bed or support, thereby further disentangling the diamagnetic particles and permitting them finally to escape to a convenient point of collection, and at the same time the paramagnetic particles are caused to travel along zigzag or wavy fields of magnetic force to a separate point of discharge or collection.

The present invention relates to apparatus of this general type effective and reliable in operation and simple and inexpensive in point of construction.

In the accompanying drawings, Figure 1 represents a front elevation of one form or embodiment of the present invention, the rotating screen or carrier being omitted. Fig. 2 represents a like view of another form or modification thereof. Fig. 3 represents a side elevation of the structure shown in Fig. 2 partly in section.

Similar letters of reference indicate similar parts throughout the several views.

Referring to the drawings, J indicates the energizing-coil of an electromagnet, and F a hollow core thereof, said core being widened at its free end to form a pole-piece A, which may conveniently be of circular contour. Through the hollow core F extends a shaft B,

of non-magnetic material, adapted to be driven by a pulley D and carrying at its outer end a disk E, of brass or other diamagnetic material. In front of the disk E and at one side of the longitudinal axis of the shaft B is located the feeding-hopper M, and below the disk are located the receiving-hoppers N and P.

As explained in my application hereinbefore referred to, zigzag or wavy fields of magnetic force are established in the pole-pieces A for the purpose of causing a rearrangement and re-formation of the magnetic particles in which the diamagnetic material is entangled or enmeshed. In the form illustrated in Fig. 1 these zigzag or wavy fields of force are obtained by providing the pole-pieces with a series of recesses arranged closely together, as shown, and extending part way through the pole-piece. In the form of the invention shown in Fig. 2 a like result is obtained by forming a series of zigzag or wavy continuous indentations in the pole-piece, as shown, which indentations may, if desired, be filled with non-magnetic material, such as lead, as shown in Fig. 3. It will be noted that in the form of the invention shown in Fig. 1 the circular recesses formed in the face of the magnet-pole are also illustrated as occupied by non-magnetic material, a construction which I prefer, for the reason that it presents an even surface which is not liable to be clogged by dust or dirt. It will also be noted that immediately beyond the series of circular recesses shown in Fig. 1 the magnet-pole is provided with a radial recess H, and that in the form shown in Fig. 2 the zigzag recesses all end at the outer edge or periphery of the magnet-pole.

The mode of operation of the invention is as follows: The material to be separated is fed from the hopper M while the disk E is being rotated toward the right. The magnet J being energized, the paramagnetic material is at once attracted by the magnet-pole and arranges itself upon the non-magnetic disk E in structures conforming to the wavy or zigzag magnetic fields of force and in a moss-like or frond-like arrangement, to produce which the strength of the current traversing the energizing-coil is appropriately adjusted.

The accompanying diamagnetic material immediately begins to become disentangled from the paramagnetic material, and as the disk E revolves the moss-like or frond-like structures are carried around with it and in crossing the wavy or zigzag magnetic lines of force rearrange themselves constantly and continuously, thereby further disengaging and freeing the diamagnetic particles. As the rotation of the disk continues the magnetic material is finally carried along to a point where it accumulates and drops off into a convenient collector—as, for instance, the hopper P. This point is determined in the apparatus shown in Fig. 1 by the radial slot H, whose presence interrupts the further progress of the paramagnetic material, and in the apparatus shown in Fig. 2 by the termination of the zigzag recesses at the periphery of the disk.

Having thus described my invention, what I claim is—

1. Apparatus for separating magnetic from diamagnetic material, comprising a magnet pole-piece grooved or recessed to produce a wavy, zigzag, or tortuous distribution of the effective lines of force, in combination with a rotatory screen revolving in front of said pole-piece; substantially as described.

2. Apparatus for separating magnetic from diamagnetic material, comprising a magnet

pole-piece grooved or recessed to produce a wavy, zigzag, or tortuous distribution of the effective lines of force, in combination with a rotatory screen revolving in front of said pole-piece, the pole-piece having a hollow core through which the shaft of the screen passes; substantially as described.

3. Apparatus for separating magnetic from diamagnetic material, comprising a magnet pole-piece, having a series of grooves or recesses extending from one portion of the pole-piece, and terminating at another portion thereof so as to produce wavy, zigzag, or tortuous fields of force terminating abruptly, in combination with a rotatory screen revolving in front of said pole-piece; substantially as described.

4. Apparatus for separating magnetic from diamagnetic material, comprising a magnetic pole-piece A, grooved or recessed to produce a wavy, zigzag, or tortuous distribution of the effective lines of force, rotatory screen E, feed-hopper M, and receiving-hoppers N, P; substantially as described.

In testimony whereof I affix my signature in presence of two witnesses.

ELMER GATES.

Witnesses:

J. E. HUTCHINSON, Jr.,

A. E. GRANT.